

Absolute rotation encoder

AAG615-8192

8192 pulse SSI



Digitronic Automationsanlagen GmbH

Auf der Langwies 1 · D - 65510 Hünstetten-Wallbach · Tel. +49 6126 9453-0 · Fax -42
Internet: <http://www.digitronic.com> · E-Mail: mail@digitronic.com

Notification

This handbook corresponds with the unit version of 12/2006. The company Digitronic Automationsanlagen GmbH reserves the right to implement changes that result in an improvement of the quality and the functions of the device at any time and without any announcements.

This instructions manual was created with a maximum of care, but mistakes are not out of the question. We are thankful for any comments, regarding possible mistakes in the instruction manual.

Update

You can also obtain this instruction manual on the Internet at <http://www.digitronic.com> in the latest version as PDF file.

Qualified personal only

Commissioning and operation of the device may only be carried out by qualified personal. Qualified personal are persons, authorized with commissioning, grounding and labeling devices, systems and electrical circuits according to the applicable standards of security

Liability

(1) The salesperson is liable for any damages for which he or the rightful owner is responsible up to the amount of the actual salesprice. Liability concerning missed profits, failed-to-appear savings, indirect damages and consequential damage is excluded.

(2) The liability restrictions above are not valid concerning assured characteristics and damages, which are caused by intention or coarse negligence.

Protection

The device AAG615-8192 and this instruction manual are protected by copyright. All rights are reserved. Neither the device AAG615-8192, nor this document may be copied as a whole or partially, photocopied, reproduced, translated or transferred to electronic media of any kind or into machine readable format without prior written permission by the company Digitronic Automationsanlagen GmbH.

Note: This device fulfills the following norms: DIN EN 61000-6-2, DIN EN 61000-4-2, DIN EN 61000-4-4, DIN EN 61000-4-5, DIN EN 61000-4-8 and DIN EN 55011 and RoHS 2 (2011/65/EU)..



(c) Copyright 1992 - 2017 / Datei: AG615_8E.DOC

Digitronic Automationsanlagen GmbH
Auf der Langwies 1
D-65510 Hünstetten - Wallbach
Tel. (+49)6126/9453-0 Fax. (+49)6126/9453-42
Internet: <http://www.digitronic.com> / E-Mail: mail@digitronic.com

1. The absolute rotation encoder AAG616-8192

Turns with a resolution of 8192 pulse can be measured by the absolute rotation encoder and can be connected through the serial synchronized data exchange to the camswitchunits of the CamCon series.

1.1. The dimensions of the components of the AAG616-8192 rotation encoder

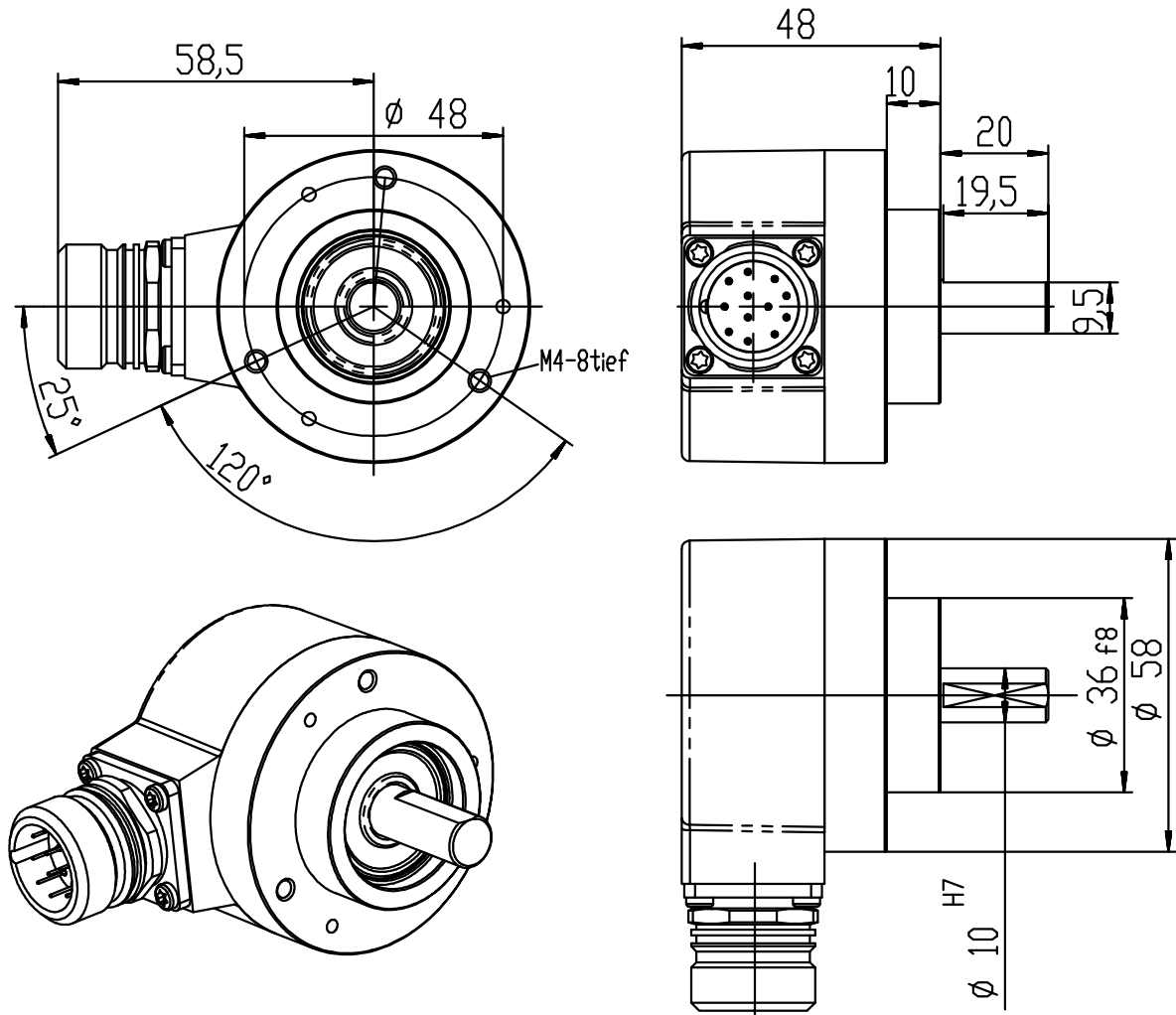

1.2. The SSI interface

The SSI interface is a common interface for absolute single and multiturn encoders. The CamCon supplies the measuring system with 24Volt via this interface. To read the data, CamCon sends a clock signal with an RS422 level to the encoder. The encoder then answers synchronously with the output (data) of the position in Gray code. The frequency of the clock signal depends on the length of the cable connecting encoder and CamCon. This value can be configured at the CamCon.

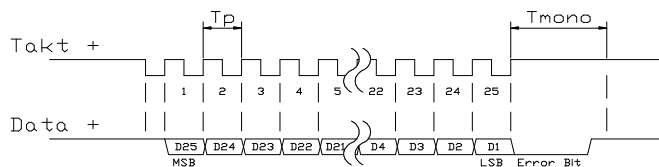

- Tp = clock impulse maximum of 2MHz to a minimum of 50kHz. (configured at the cable length setting)
- Tmono = mono flop time > 15µs

1.3. The terminal assignment of the AAG615-8192 rotation encoder

Connection plug
Type: AAG615-8192/ST
Binder Series 623
soldering side

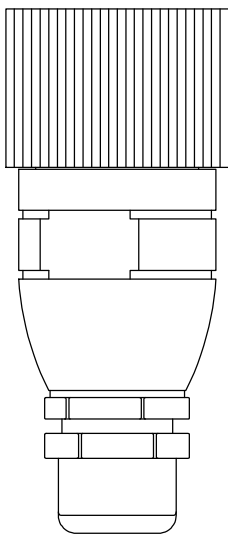
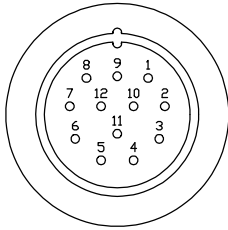

Attention: The order of the numbering of the connector plug may differ from manufacturer to manufacturer. You can only connect a plug with a different order, if you keep the displayed attachment allocation in mind. The location of the pins has to match the corresponding functions at the device. This booklet uses a plug of the Binder 623 series.

Attention: Connecting wrong poles of the connection cables can damage or destroy the CamCon or the encoder.

The connection plug of the SSI interface is dependant of the type of the CamCon. Consult the handbook of your CamCon.

connection plug Type: AAG615-8192/ST
Binder series 623

Encoder Type: AAG615-8192

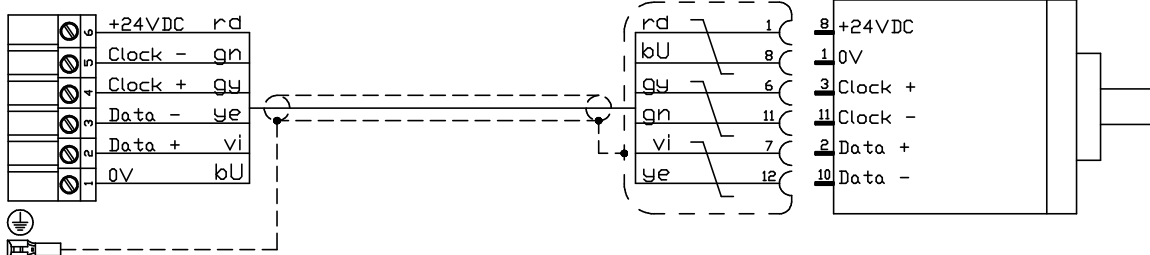

max. cable length: 300m
cable type: LIYCY 4x2x0.25 + 2x0.5 + shield

Please note: Only use a sheathed pairwise connection cable. Do not put the cable near power current wires. If possible, put the screening up at both sides.

order number: KKyy/S-XX meter

yy = CamCon typ for example 16,33,40,50,60,90,115,190,300 or 1756
XX = Length of the cable in meter

2. Installation and bringing into service

Rotation encoders are precision measuring units and therefore have to be handled as such. Please regard the following installation instructions before bringing the rotation encoder into service.

- When installing the rotation encoder, pay attention to the slight angular and radial misalignment. (See technical data of the to be used couplings). Avoid blows towards the shaft and regard the values concerning the shaft loads, which are listed on the data sheet.
- Use flexible couplings ! The kind of couplings is determined by the speed, the torque, and the to be by-passed angular and radial misalignment.
- Connect the rotation encoder to the corresponding terminal assignment. See to it, that the operating voltage recommended on the type plaquette is installed.
- The plug should not be connected or disconnected when under voltage.
- If the rotation encoder, even if correctly installed, does not function properly, intermittent faults can be the cause of that. Such faults are due to power supply switchings, pulse mode controllers or motors etc. Such faults can be reduced through proper protection facilities and through using cables with a better shielding or an appropriate filtering network.
- Should the occasion arise, protect the rotation encoder against environmental damage. (solid particle impact, water spray ect.).
If any interventions are carried out by unauthorized personnel the factory guarantee becomes invalidated !

Please review the wiring of the unit before switching it on and then engage the supply voltage of the CamCon.

2.1. Technical data of the AAG615-8192 rotation encoder

Voltage supply.....	24VDC +-20%
Power consumption (without load).....	max. 20 mA
Resolution (Singleturn).....	8192 steps (13Bit)
Data output.....	synchronos serial (SSI), graycode
Monofloptime	> 15µs
Cablelength between rotation encoder and CamCon.....	300 meter max.

Mechanical characteristics

Valid torque	maximum 5000 min ⁻¹
Inertia of the rotor.....	approx. 3x10 ⁻⁶ kgm ²
Start-up torque	<0.01 Nm
Shaft load.....	axial 40 N / radial 80 N
Vibration solidness	>100m/s ² , 10...2000 Hz
Acceleration solidness	>2500 m/s ² , 6ms
Protection.....	IP 65 / Case IP 67
Operating temperature.....	-40°C..+90°C
Weight.....	about 350 g.

3. The shaft couplings

Encoders are precision measuring units and therefore have to be kept apart from the vibrations and tremors, as well as the from the misalignment of the machine. To part the encoder from these influences use the flexible shaft couplings.

3.1. Wendel - shaft couplings type: WK/A/10-10

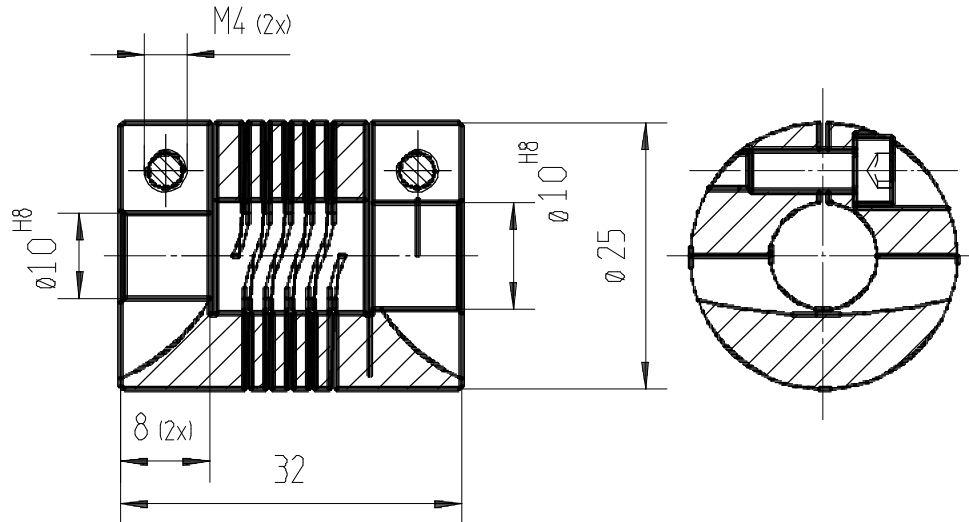

3.1.1. Technical data

Outer diameter	25 mm
Length	32 mm
Clamp-screw	M4
Nominal torsial moment	120 Ncm
Acceptable radial shift	+/- 0.35 mm
Acceptable axial shift	+/- 0.5 mm
Acceptable angle-shift	+/- 4 degree
Torsions strength	16 Nm/rad
Acceptable rotation speed	6000 U/min
Weight	ca. 34g

3.2. The shaft couplings WK/K/10-10

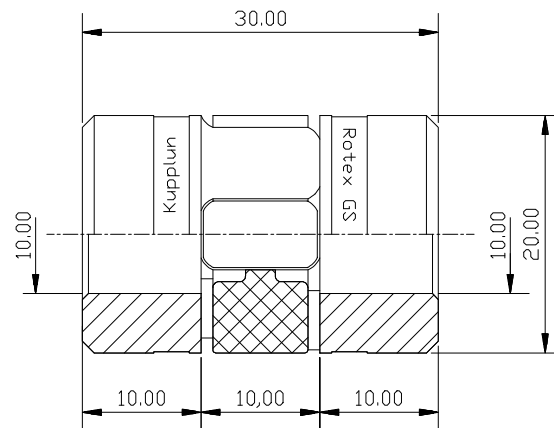

3.2.1. Technical data

Outer diameter	20mm
Length	29,5mm
Clamp screw	M 2,5
Standart torque	1,94 Nm
Valid radial shift.....	+/- 0,13 mm
Valid axial shift	+/- 0,8 mm
Valid angular misalignmen.....	+/- 1 Grad
Torsion stiffness.....	31,5 Nm/rad
Valid torque	28000 min ⁻¹
Weight.....	20 g

3.3. Isolting springdisks - shaft coupling type: WK/D/10-10

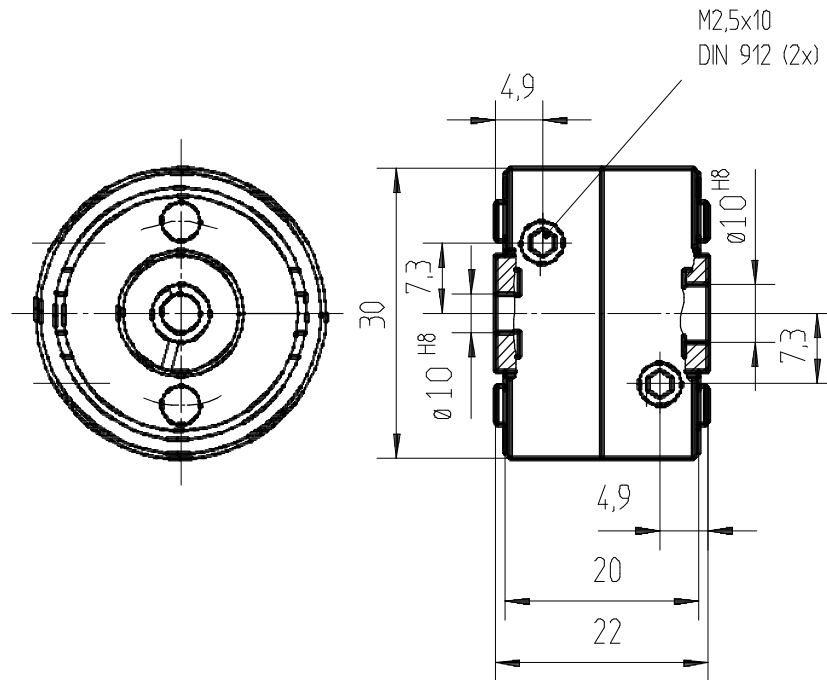

3.3.1. Technical data

Outer diameter	30 mm
Length	22 mm
Clamp-screw	M2.5
Nominal torsial moment	40 Ncm
Acceptable radial shift	+/- 0.4 mm
Acceptable axial shift	+/- 0.4 mm
Acceptable angle-shift.....	+/- 2.5 Grad
Torsions strength	90 Nm/rad
Acceptable rotation speed.....	12000 U/min
Weight.....	ca. 23 g

4. Clamping

4.1. Angle flange type: WF/AG

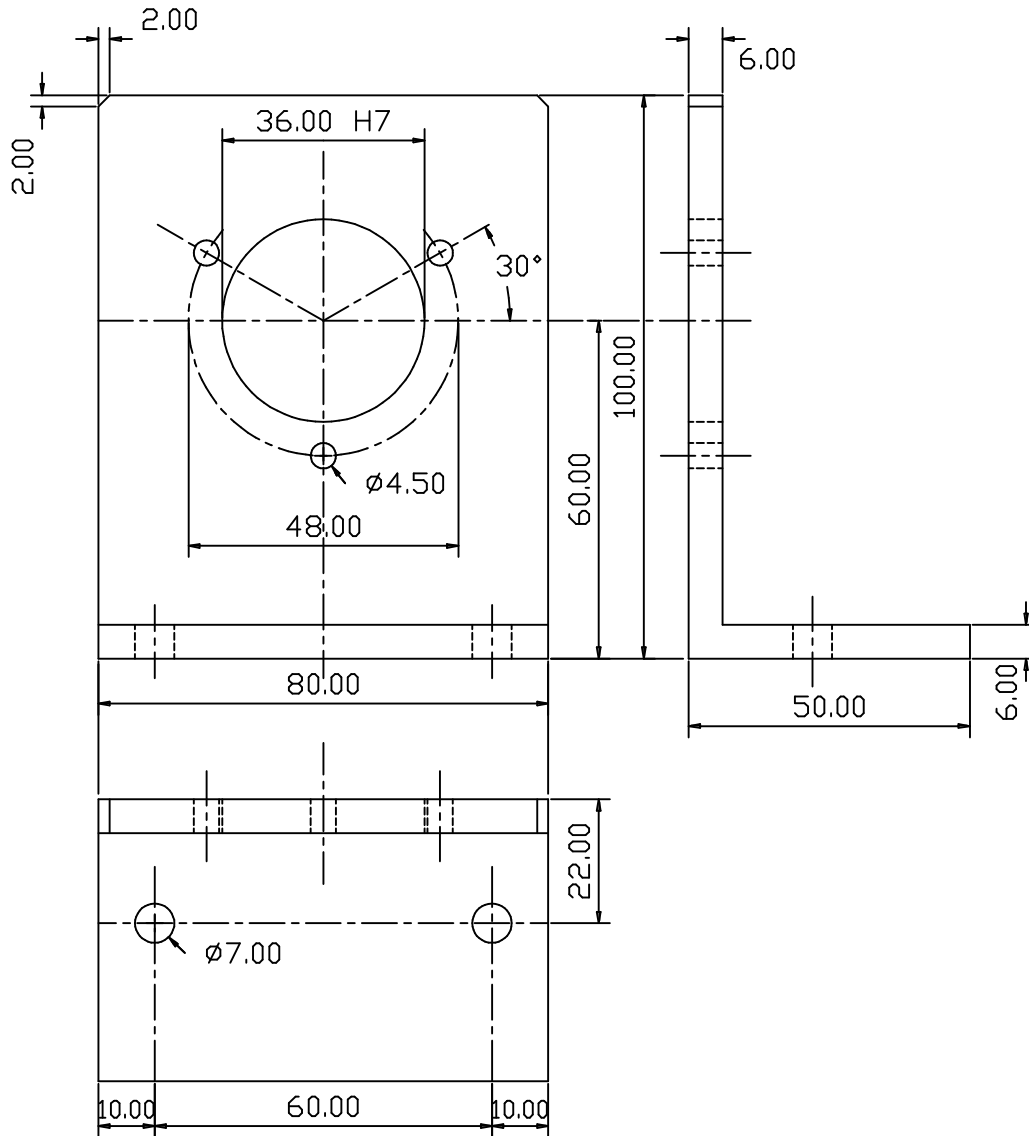

4.1.1. Technical data

Suitable for AAG60007, AAG612, AAG626, AAG66107,
AAG615 and ADG60 i.e. all turn-angle-encoder
with 48 mm partial circle, 36 mm flange and 10 mm
shaft.

Clamping of the turn-angle-encoder by three DIN 912 M4x12mm screws.

Weight..... approximately 180g.

4.2. Bearing trestle: LAG60

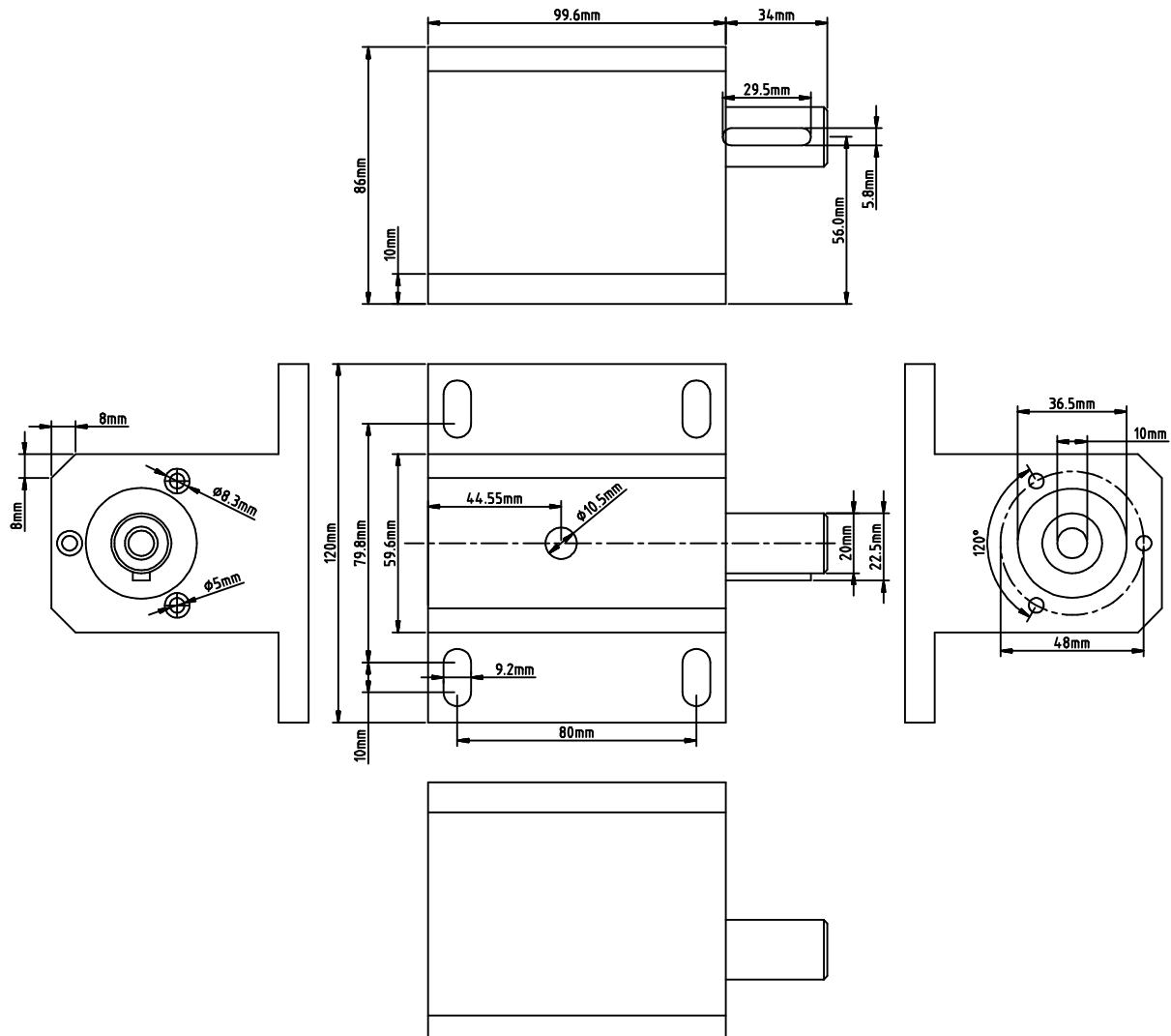

4.2.1. Technical data

- Suitable for AAG60007, AAG612, AAG626, AAG66107, AAG615 and ADG60 i.e. all turn-angle-encoder with 48 mm partial circle, 36 mm flange and 10 mm shaft.
- Acceptable rotation speed..... 3000 U/min.
- Shaft drive 20mm with closed shaft notch.
- Shaft drive 10mm to the turn-angle-encoder with shaft coupling WK/K/10-10.
- Bearing 2 pieces, maintenance free groove - ball bearings.
- Clamping of the tiurn angle encoder by 3 DIN 912 M4x40mm screws.
- Weight approximately. 1.5kg.